

SENSOR OPTION C

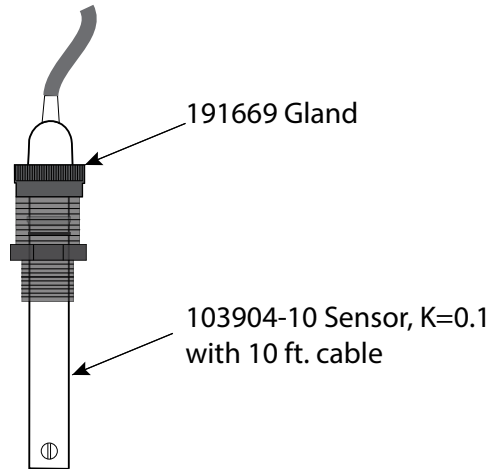

SENSOR OPTION A, B, D

191631-20 Cable, 20 ft

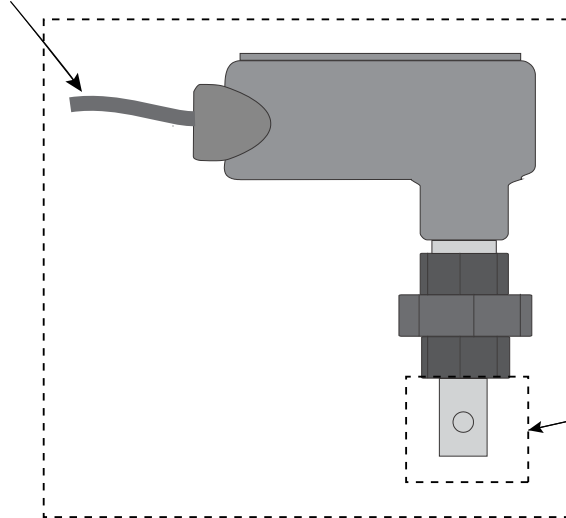

A = 190762
B = 190762-NT
D = 191089

A = 191694 Sensor, K=1.0 with ATC* & Instructions
or 190768 Sensor, K=1.0, with ATC (no instructions)
B = 103262 Sensor, K=1.0, no ATC
D = 103063 Sensor, K=10 with ATC

* ATC= Automatic Temperature Compensation

WBL Sensor options A,B,C,D

- A: Boiler sensor with ATC, 250 psi, 1.0 cell constant, 20 ft. cable
- B: Boiler sensor without ATC, 250 psi, 1.0 cell constant, 20 ft. cable
- C: Condensate sensor with ATC, 200 psi, 0.1 cell constant, 10 ft. cable
- D: Boiler sensor with ATC, 250 psi, 10 cell constant, 20 ft. cable